

DOT PEEN MARKING MACHINE

e10 c153 za



+ HIGH ACCURACY OF MOVEMENT

- Quality and precision of guidance (0,02 mm)
- Speed (up to 3000 parts per day)
- Powerful integrated software
- LED lighting

+ MOTORIZED Z AXIS WITH INTEGRATED BRAKE

- Automatic Z-axis movement / Stroke 250mm
- High precision ball screw design
- Safety in case of power failure
- Control by e10 controller

+ ROBUST AND RELIABLE

- Cast aluminum base
- Mechanics and stylus assembly designed for intensive use

FONCTION AUTOSENSING (c153 + autosensing option)

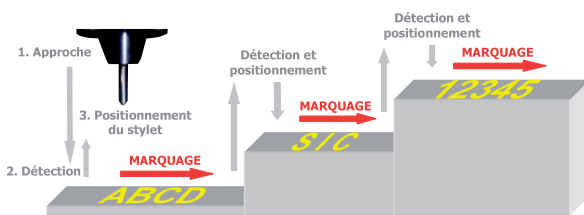

+ Repeatability

+ Automatic surface detection

+ Autosensing system for high quality and reliable marking over time

APPLICATIONS

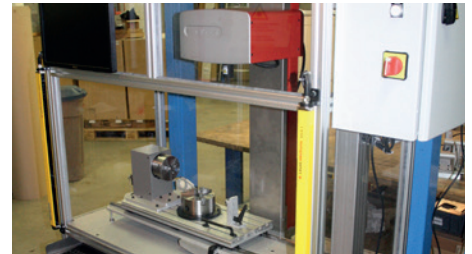
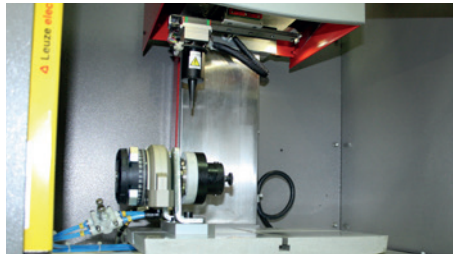
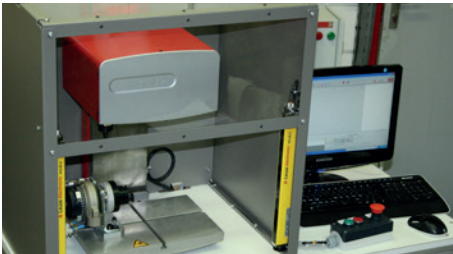

DOT PEEN MARKING EXAMPLES



TECHNICAL & MECHANICAL FEATURES

e10 c153 za

Marking window	160 x 100 mm- 6.3 in x 3.9 in
External dimensions	385 x 350 x 636 mm- 15.2 x 13.8 x 25 in
Weight	30 kg - 66 lbs
Stylus	Tungsten carbide 60 mm- 2.4 in
Machine / controller cable length	2,5 m- 6.5 ft
Z axis speed	30 mm/sec.

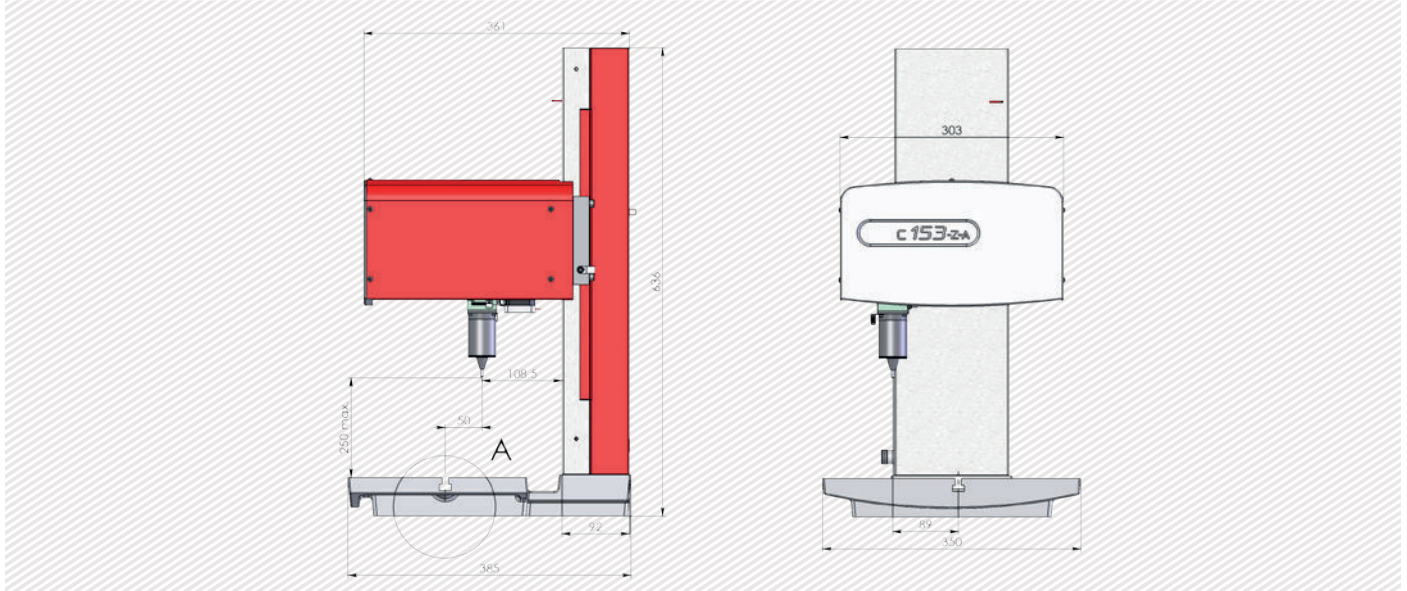

OPTIONS



Rotary axes

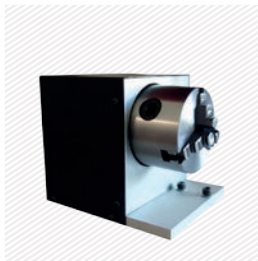

Plate support



Tag feeder



Datamatrix reader



Wireless barcode reader

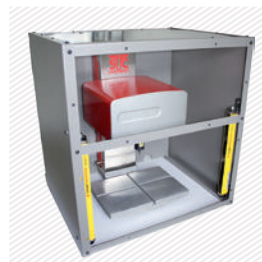

Protective box with light curtains



Maintenance kit



Wide range of stylus



Starting cycle pedal

Please consult us if a specific configuration is not published in the table attached. SIC Marking designs customized and turnkey solutions for all industrial sectors. Our design offices produce machines in compliance with your specifications and your industrial standards.

E10 CONTROL UNIT

The e10 controller

- Color screen
- USB Port: to easily upload / download your marking files
- Fully programmable
- Standalone (no PC needed)
- Membrane protected industrial Keyboard
- IP40 waterproof box (no opening or fan)



+ Multiple connectivities



+ Color screen



+ USB Port



Technical & electronic features

e10 Controller	
Dimensions	322 x 380 x 112 mm - 13.7 x 15 x 4.4 in
Weight	5 kg - 11lbs
LCD screen resolution	480 x 272 pixels
Keyboard	Qwerty integrated, protected by membrane
Power	300 Watt
Power supply	Single phase, 85 to 260 VAC, 50 to 60 Hz
Controlled axes	2 (optional 3rd / 4th axis card)
Operating temperature	From 5 to 40°C

Communication	
Communication ports	RS232, RS422, USB, RS485 Profibus, TCP/IP, Ethernet/IP
Inputs-outputs	8/8
External keyboard input	USB
PC software	Creation of marking files, transfer controller / PC or USB key

Optional communication cards:



PC UTILITIES

File editor

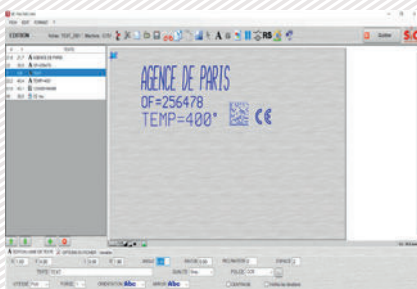

+ Creation or modification of files on PC.

Creation of logos



+ Creation of vector and matrix logos.

Creation of logos

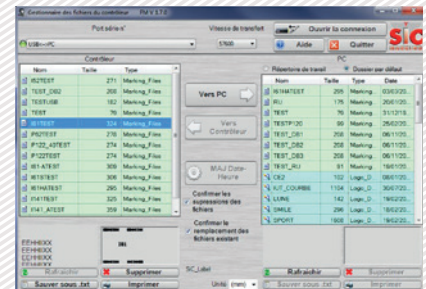

+ Backup and file transfer utility.

E 10 RANGE SOFTWARE

Software features

Text function	Incrementation, date codes
Logos	Download from a PC or USB key
Datamatrix	Up to 348 characters, 48 x 48 dots
Fonts	Arial, Comic, Comic_B, Courier, OCR, OCR_BOLD, OCRA, 4x6
Style	Angular, Radial, Inverse, and Mirror
Character Size	From 0,1 mm to 99 mm (limited following marking window)
Depth	Up to 0,3 mm (according to the material)
Resolution Between Dots	0,05 mm MAX
Password	2 security levels
History function	Exportable Excel file
Help with maintenance	Auto diagnosis
Available languages	17



Graphic view



Edit menu

AFFECTATION DES I/O		
Num	Entrée	Sortie
1	ARRET	Cycle
2	DEPART	Dernier
3	Sel. Fich	Erreur
4	Sel. Fich	Pause
5	Sel. Fich	Prêt
6	Sel. Fich	PasPièce
7	Sel. Fich	Pièce
8	Sel. Fich	Usure

STATISTIQUES CONTROLEUR	
Déplacements	Mémoire
0 Cycles	33 Fichiers
0 Caractères	17959 o. Utili.
AXE X 0.0 m	46409 o. Libres
AXE Y 0.0 m	27% Utilisées
AXE Z Num. 0.0 m	
Impacts	
F1: 0	F4: 0
F2: 0	F5: 0
F3: 0	F6: 0
F7: 0	F8: 0
F9: 0	

PC software for directly controlling the marking machine.

Available functions:

- Editing of marking files
- Input / output management
- History function and anti duplicates
- Datamatrix ECC200 and UID
- ...

OPTIONAL WINSIC SOFTWARE

WINSIC is a PC software for direct control of the marking machine.

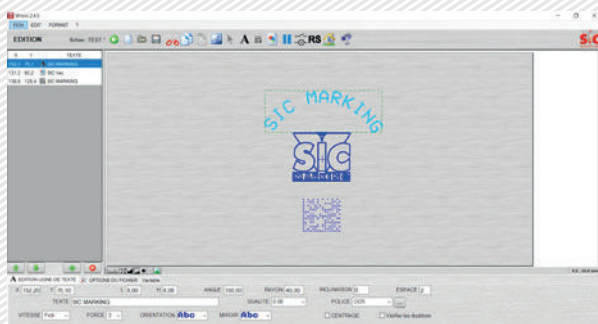

+ Built-in logo design utility

+ Database Management (Excel, Access, txt)

+ Insertion of background images

