

DOT PEEN MARKING MACHINE

e10 i83

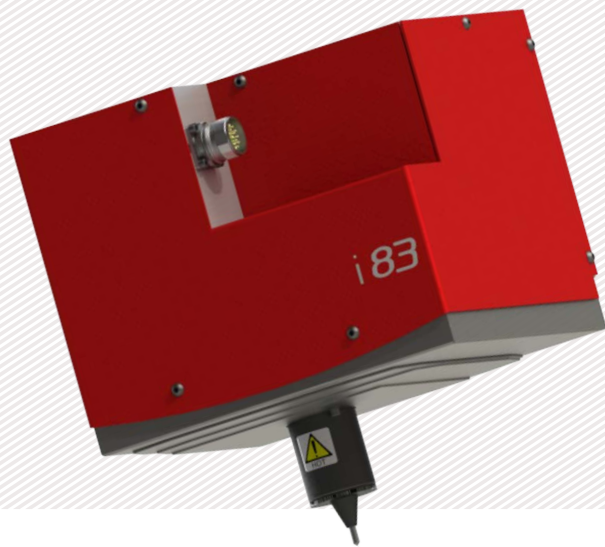

+ SPEED AND PRECISION

- High quality, precise guides (accurate within 0.02 mm)
- High performance software

+ ROBUST AND RELIABLE

- Hidden connector
- Mechanical stylus assembly designed for intensive use
- Integrated vision system (for i83V and i83VA)

+ VERY COMPACT

- Dimensions: 225 x 202 x 256 mm - 8.8 x 7.9 x 10 in
- Large marking window: 80 x 70 mm - 3.1 x 2.7 in

E 10 I83 A CONFIGURATION

(i83 + autosensing option)

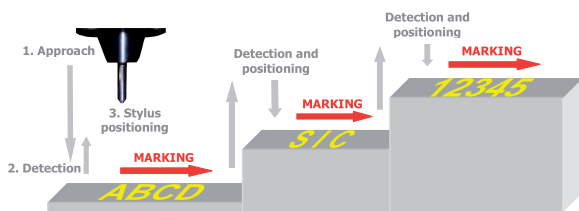

- Repeatability
- Automatic surface detection
- Autosensing system for high quality and reliable marking over time
- Associated with a z axis

E 10 I83 V CONFIGURATION

(i83 + integrated camera)



Possibility of combining the two configurations >> e10 i83 V-A

DOT PEEN MARKING EXAMPLES



TECHNICAL & MECHANICAL FEATURES

	e10 i83	e10 i83 A	e10 i83 V	e10 i83 VA
Marking window	80 x 70 mm- 3.1 x 2.7 in	80 x 70 mm- 3.1 x 2.7 in	80 x 70 mm- 3.1 x 2.7 in	80 x 70 mm- 3.1 x 2.7 in
External dimensions	225 x 202 x 256 mm - 8.8 x 7.9 x 10 in	225 x 202 x 275 mm - 8.8 x 7.9 x 10.8 in	225 x 202 x 256 mm - 8.8 x 7.9 x 10 in	225 x 202 x 275 mm - 8.8 x 7.9 x 10.8 in
Weight	9,4 kg - 19.8 lbs	9,4 kg - 19.8 lbs	9,6 kg- 19.9 lbs	9,6 kg- 19.9 lbs
Stylus	60 mm - 2.4 in (80 or 100 mm - 3.1 or 3.9 in optional)	60 mm - 2.4 in	60 mm - 2.4 in	60 mm - 2.4 in
Part detection	no	yes	no	yes
Camera	no	no	1D and 2D decoding, 640 x 480 px (1600 x 1200 px optional)	1D and 2D decoding, 640 x 480 px (1600 x 1200 px optional)
Reading area	no	no	15 x 15 mm - 0.6 x 0.6 in	15 x 15 mm - 0.6 x 0.6 in
Protective Bellows	yes	yes	partial	partial

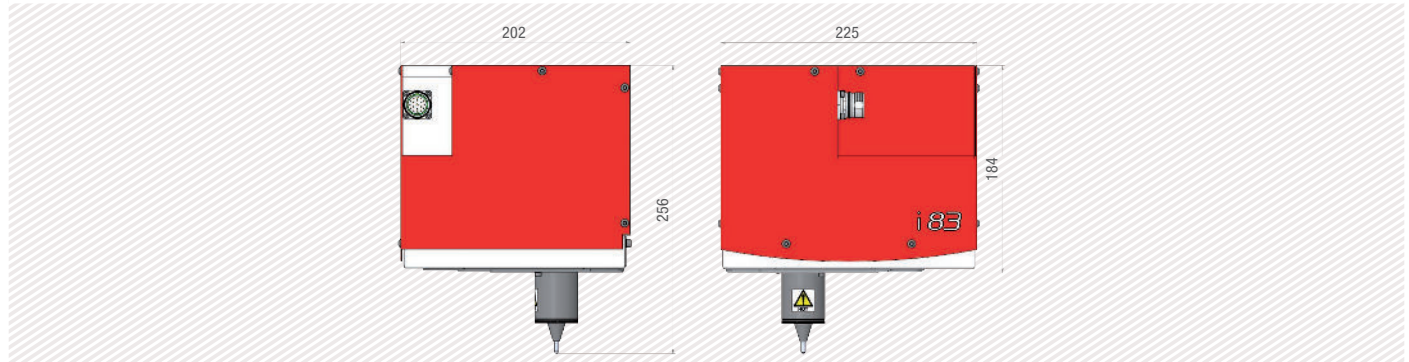

APPLICATIONS

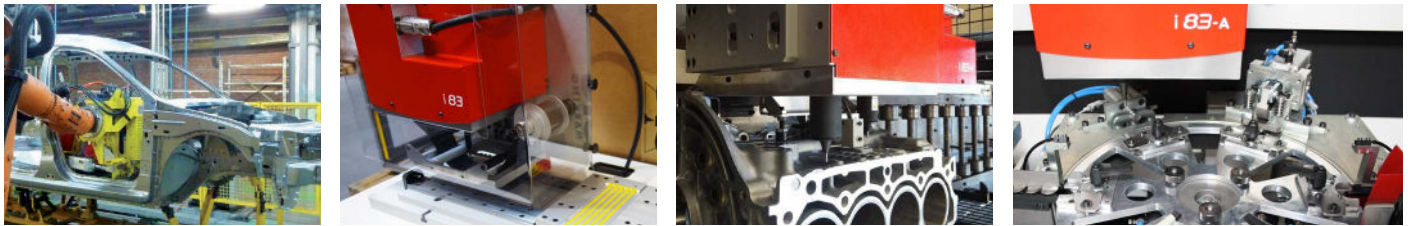

OPTIONS

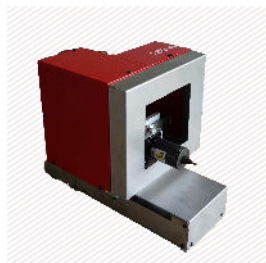

Z axis 50 to 250 mm



DIN rail kit for e10R controller

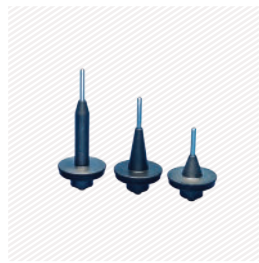

Wide range of stylus

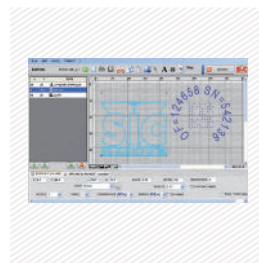

PC software



Maintenance kit



Datamatrix reader



Wireless barcode reader

Please consult us if a specific configuration is not published in the table attached.

SIC Marking designs customized and turnkey solutions for all industrial sectors. Our design offices produce machines in compliance with your specifications and your industrial standards.

E10 CONTROL UNIT

The e10 controller

- Color screen
- USB Port: to easily upload / download your marking files
- Fully programmable
- Standalone (no PC needed)
- Membrane protected industrial Keyboard
- IP40 waterproof box (no opening or fan)



+ Color screen

+ USB Port



+ Multiple connectivities



+ PC software and utilities



Technical & electronic features

e10 Controller		Communication	
Dimensions	322 x 380 x 112 mm - 13.7 x 15 x 4.4 in	Communication ports	RS232, RS422, USB, RS485 Profibus, TCP/IP, Ethernet/IP
Weight	5 kg - 11lbs	Inputs-outputs	8/8
LCD screen resolution	480 x 272 pixels	External keyboard input	USB
Keyboard	Qwerty integrated, protected by membrane	PC software	Creation of marking files, transfer controller / PC or USB key
Power	300 Watt	Optional communication cards:	
Power supply	Single phase, 85 to 260 VAC, 50 to 60 Hz	Ethernet TCP	
Controlled axes	2 (optional 3rd / 4th axis card)		 
Operating temperature	From 5 to 40°C		

PC UTILITIES

File editor

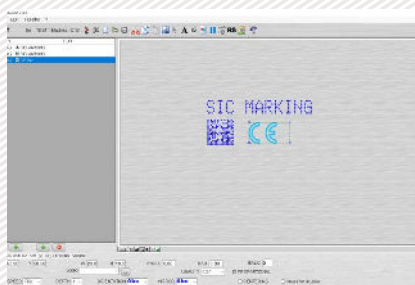

+ Creation or modification of files on PC.

Creation of logos

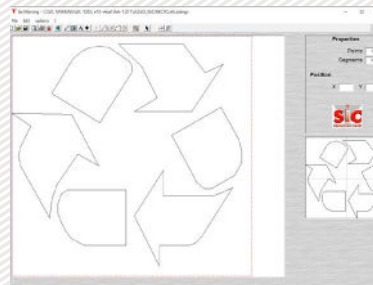

+ Creation of vector and matrix logos.

Creation of logos

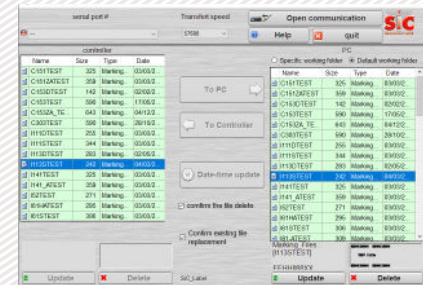

+ Backup and file transfer utility.

E10 RANGE SOFTWARE

Software features

Text function	Incrementation, date codes
Logos	Download from a PC or USB key
Datamatrix	Up to 348 characters, 48 x 48 dots
Fonts	Arial, Comic, Comic_B, Courier, OCR, OCR_BOLD, OCRA, 4x6
Style	Angular, Radial, Inverse, and Mirror
Character Size	From 0,1 mm to 99 mm (limited following marking window)
Depth	Up to 0,3 mm (according to the material)
Resolution Between Dots	0,05 mm MAX
Password	2 security levels
History function	Exportable Excel file
Help with maintenance	Auto diagnosis
Available languages	17



Graphic view

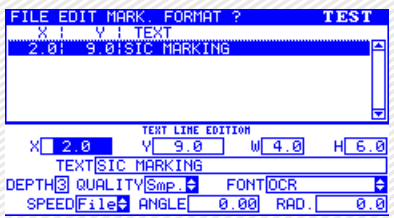

Edit menu

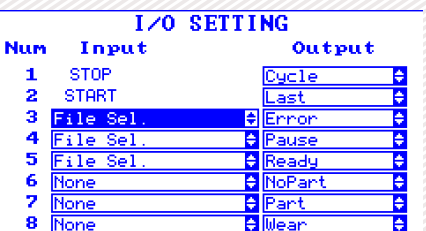
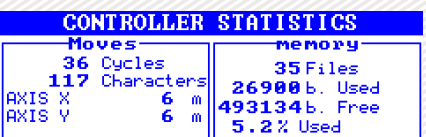
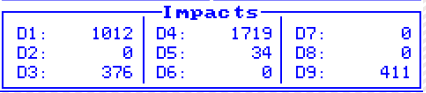
PC software for directly controlling the marking machine.

Available functions:

- Editing of marking files
- Input / output management
- History function and anti duplicates
- Datamatrix ECC200 and UID
- ...

OPTIONAL WINSIC SOFTWARE

WINSIC is a PC software for direct control of the marking machine.



+ Built-in logo design utility

+ Database Management (Excel, Access, txt)

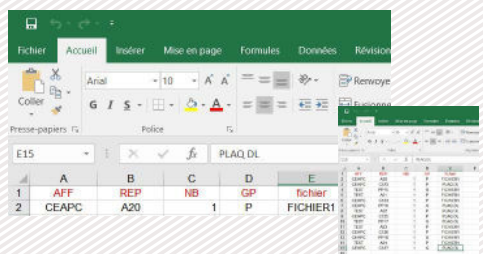

+ Insertion of background images

